

ML-MC1640BR-16C-G

ML-BR-G series



Drawing No. A24375

レンズ形式	Lens Type	Macro Lens
光学倍率	Magnification	0.03~0.09
焦点距離 (mm)	Focal Length	16.22~15.26
Fno	Fno	4.00
NA	Numerical Aperture	-
WD/OD (mm)	Working/Object Distance	550.0~150.0 / 556.5~156.5
O/I (mm)	Object to Image Distance	609.66~210.98
鏡筒長 (mm)	Mechanical Tube Length	40.80~42.00
レンズバック (mm)	Lens Back	16.92~16.95
被写界深度 (mm)	DOF @PCoC ϕ 0.04mm	396.415~37.276
分解能 (μ m)	Resolution @ λ =550nm	-
前側/後側主点位置 (mm)	Front/Rear Principal Position	20.48~20.56 / 0.26~0.33
入射/出射瞳位置 (mm)	Entrance/Exit Pupil Position	13.49~13.73 / -12.03
入射/出射瞳径 (mm)	Entrance/Exit Pupil Diameter	4.02~3.90 / 7.06
画角 (deg.) H×V	Angle Of View @WD=550	21.97 × 16.57(1/2 Inch) 29.89 × 22.64(2/3 Inch) 43.41 × 33.24(1 Inch)
TVディストーション (%)	TV Distortion @WD=550	\leq -0.046(1/2 Inch) \leq -0.055(2/3 Inch) \leq 0.073(1Inch)
周辺光量比 (%)	Relative Illumination @WD=550	\geq 95.04(1/2 Inch) \geq 90.76(2/3 Inch) \geq 66.20(1Inch)
質量 (g)	Weight	63.5
マウント	Mount	C Mount
イメージサークル径 (mm)	Image Circle	ϕ 16.4
最大適合カメラ	Largest Compatible Camera	1 Inch

ML-MC1640BR-16C-G

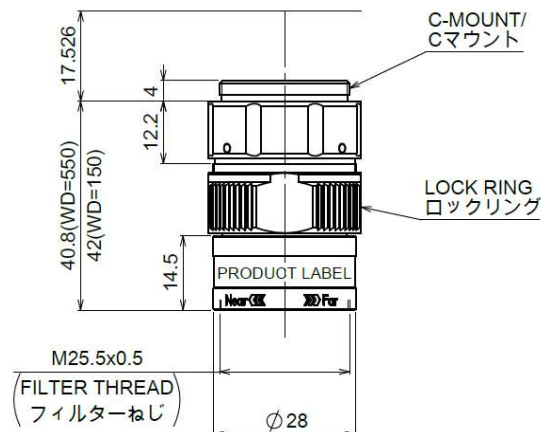

0.03x Fno4.0

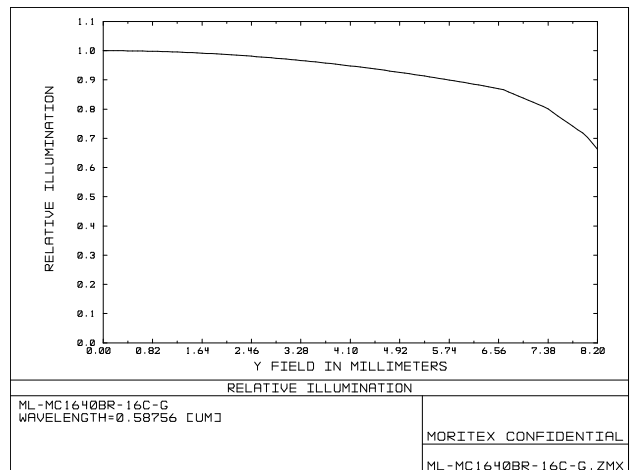
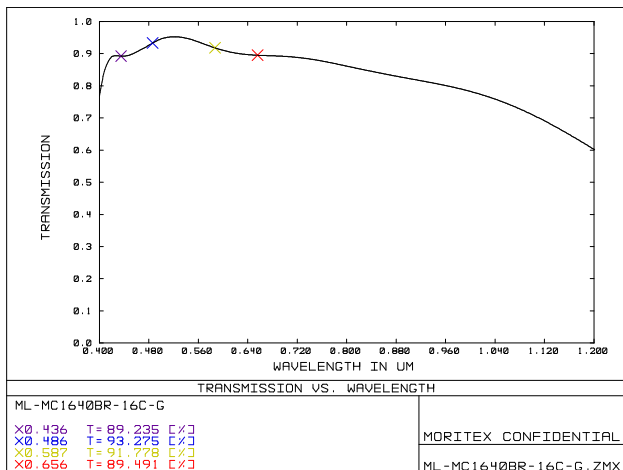
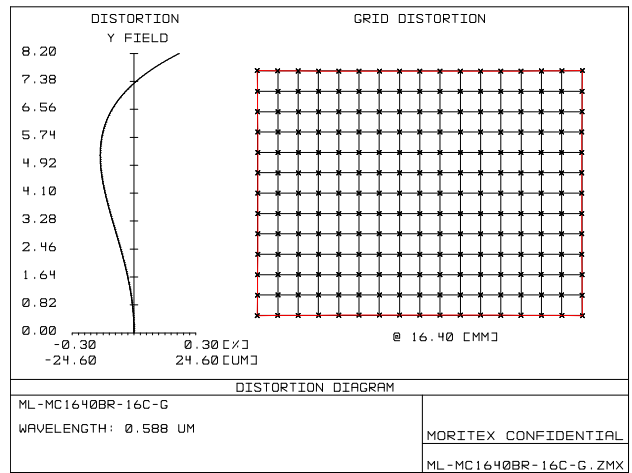
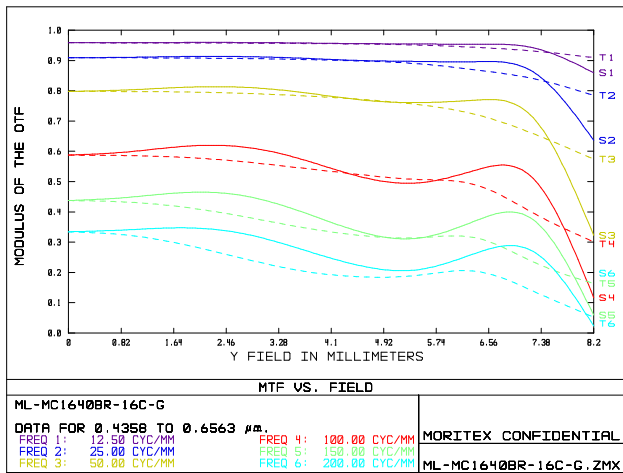

内容は、通知なしに随時変更されることがあります。

The content is subject to change at any time without notification.

株式会社 **モリテックス** MORITEX Corporation

Technology center Lens design & Development technology

TEL +81 (0)45-913-5800 moritex.mvs@moritex.com

www.moritex.com



0.04x Fno4.0

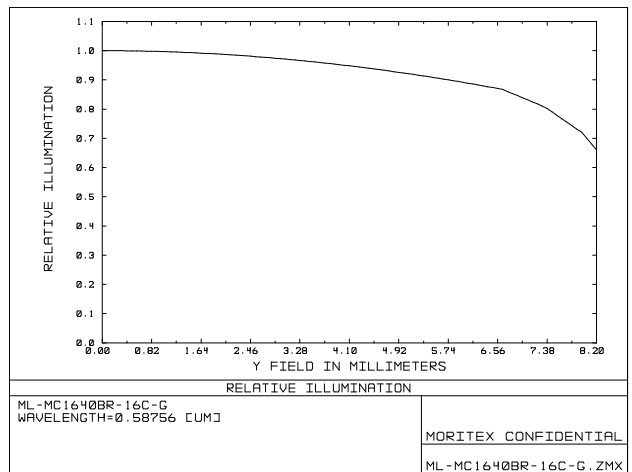
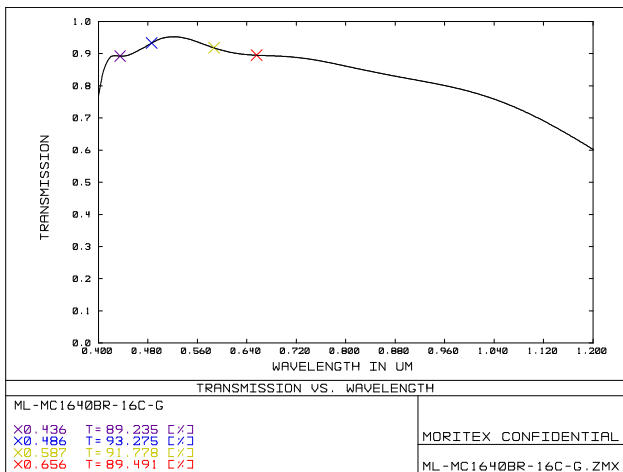
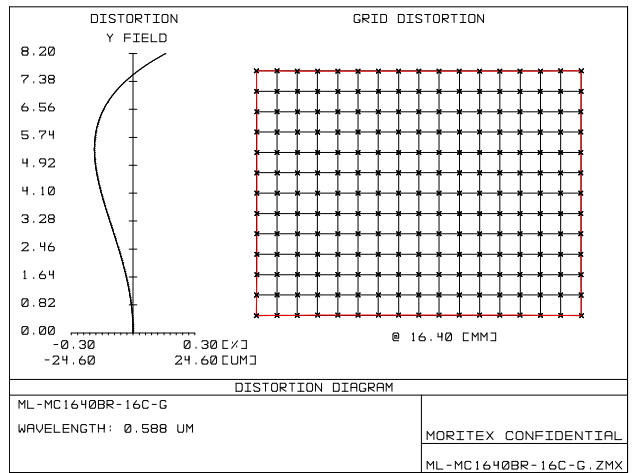
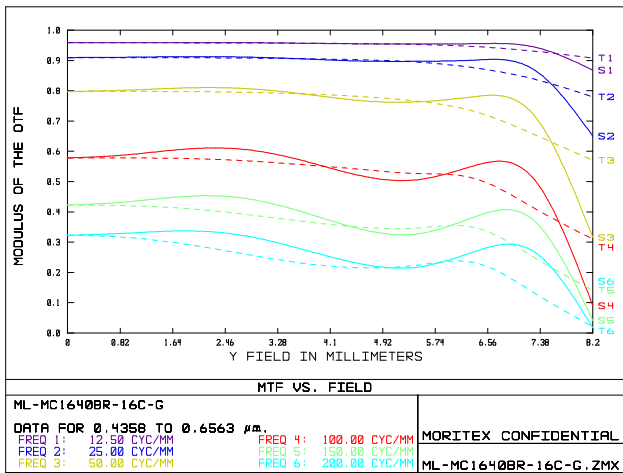

内容は、通知なしに随時変更されることがあります。

The content is subject to change at any time without notification.

株式会社 **モリテックス** MORITEX Corporation

Technology center Lens design & Development technology

TEL +81 (0)45-913-5800 moritex.mvs@moritex.com

www.moritex.com



0.09x Fno4.0

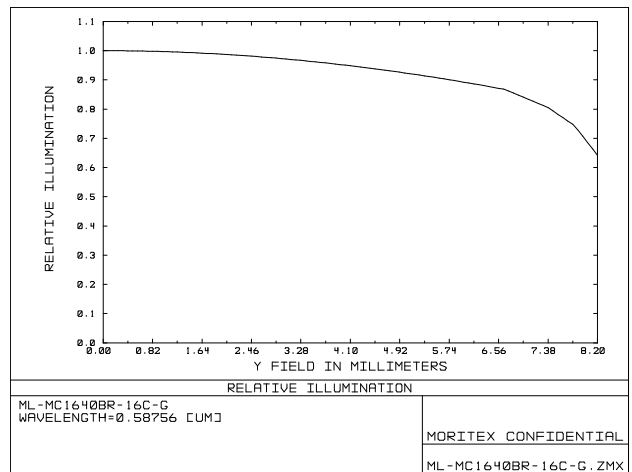
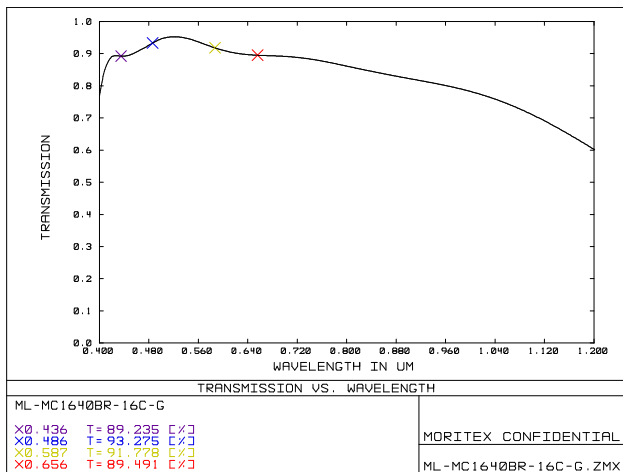
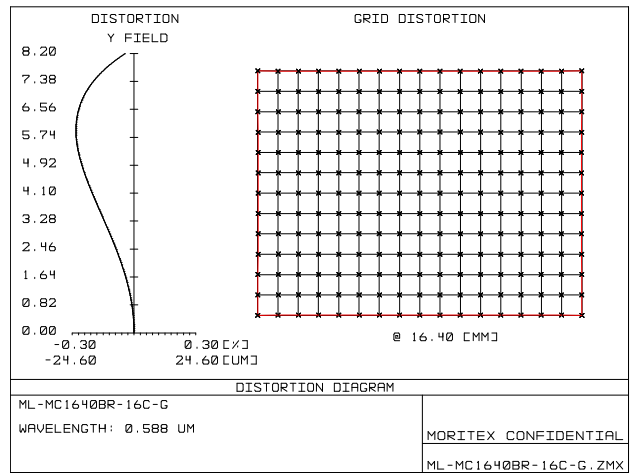
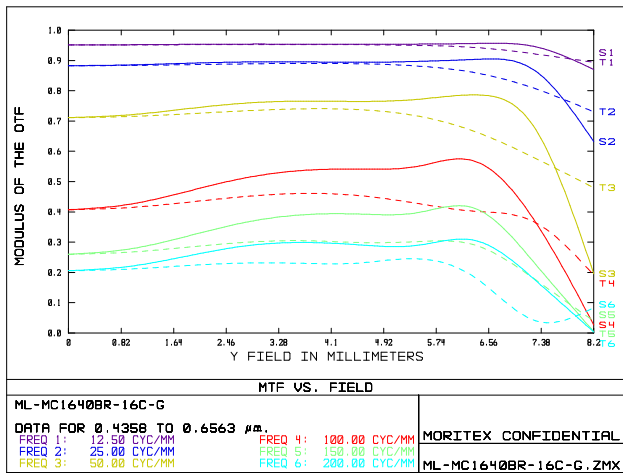

内容は、通知なしに随時変更されることがあります。

The content is subject to change at any time without notification.

株式会社 **モリテックス** MORITEX Corporation

Technology center Lens design & Development technology

TEL +81 (0)45-913-5800 moritex.mvs@moritex.com

www.moritex.com

